

- Note that the opinions expressed within the abstracts and presentations are those of the authors/presenters alone and do not necessarily reflect the opinions of WADA.

THE MITOCHONDRION POWER PLANTS: A TARGET FOR PERFORMANCE ENHANCING GENE THERAPY

Douglas C. Wallace

Center for Molecular and Mitochondrial Medicine and Genetics, UCI

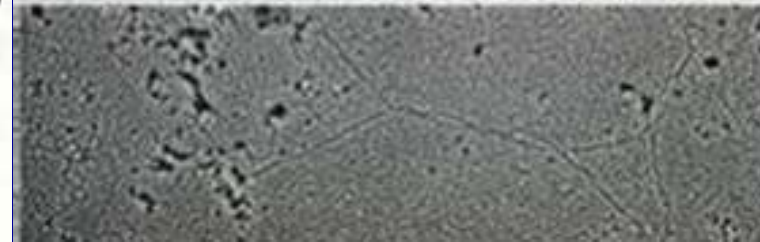
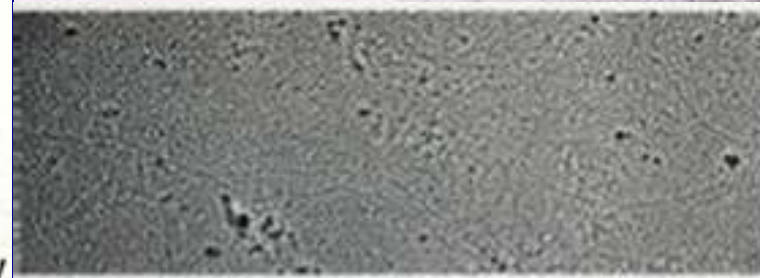
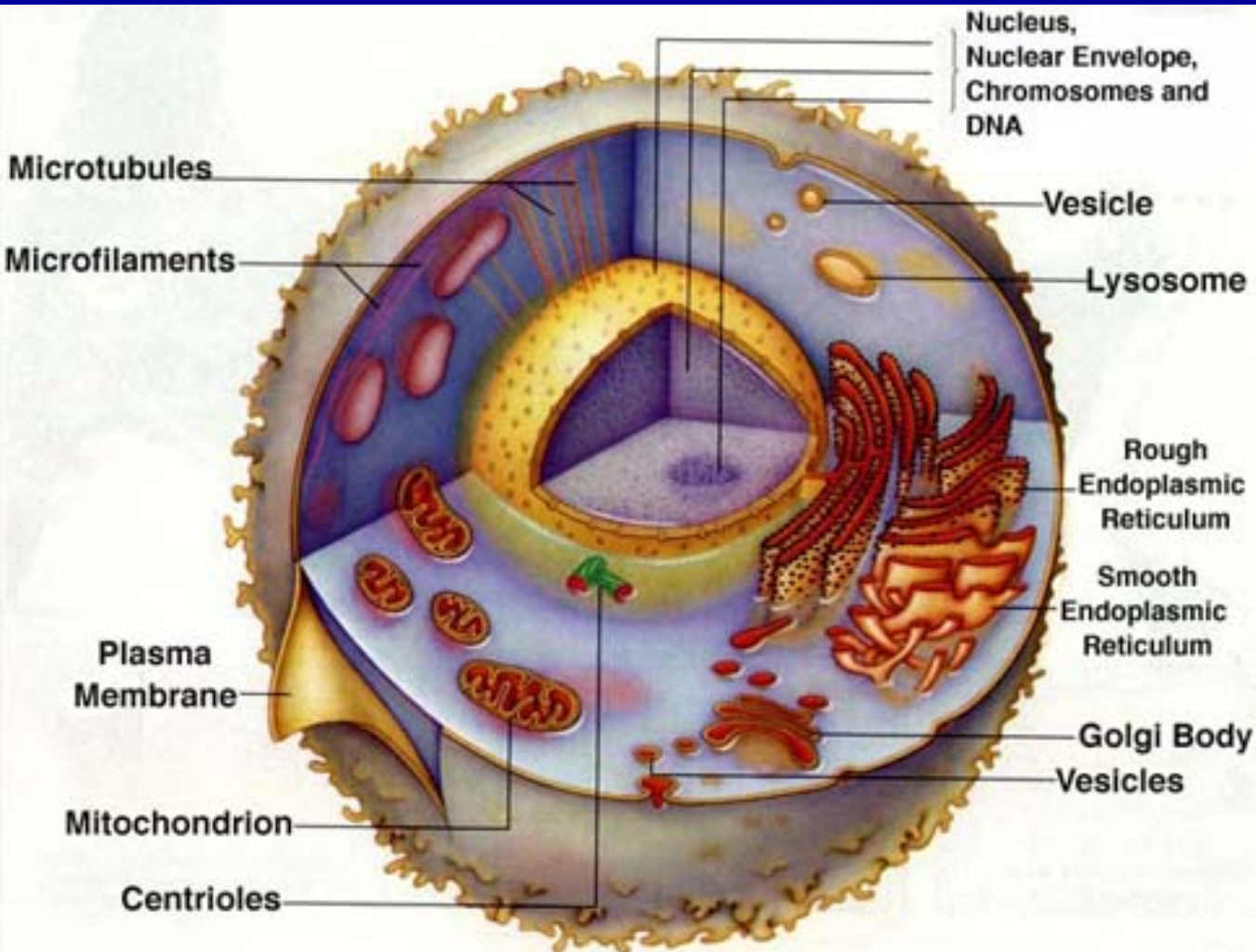

MITOCHONDRIAL GENETICS

THE MITOCHONDRIAL GENOME:

~ 1500 Chromosomal Genes

37 mtDNA Genes

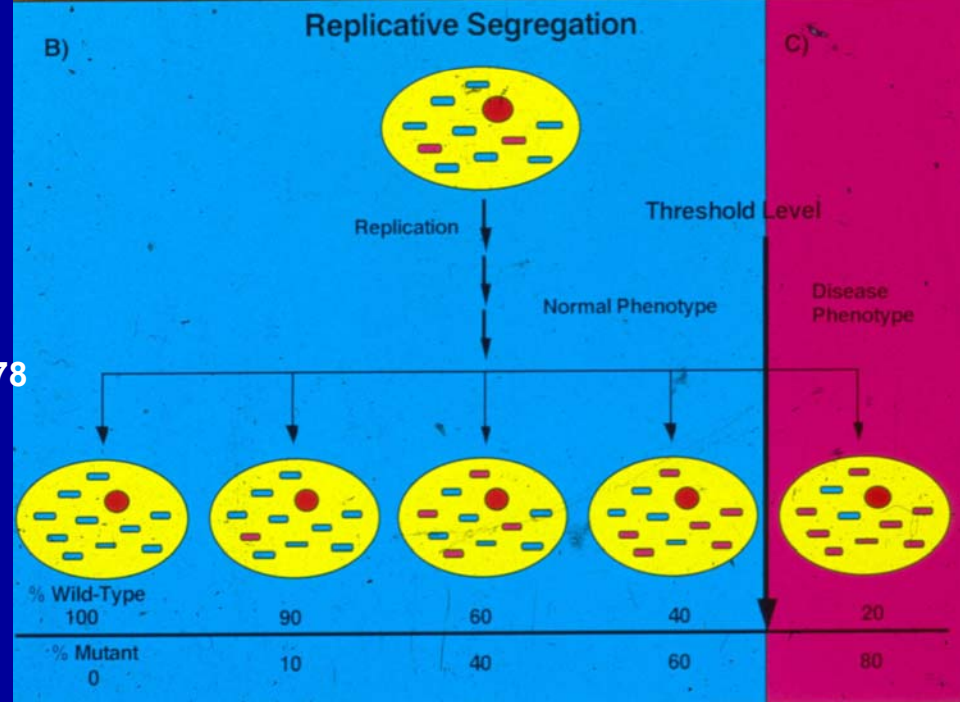
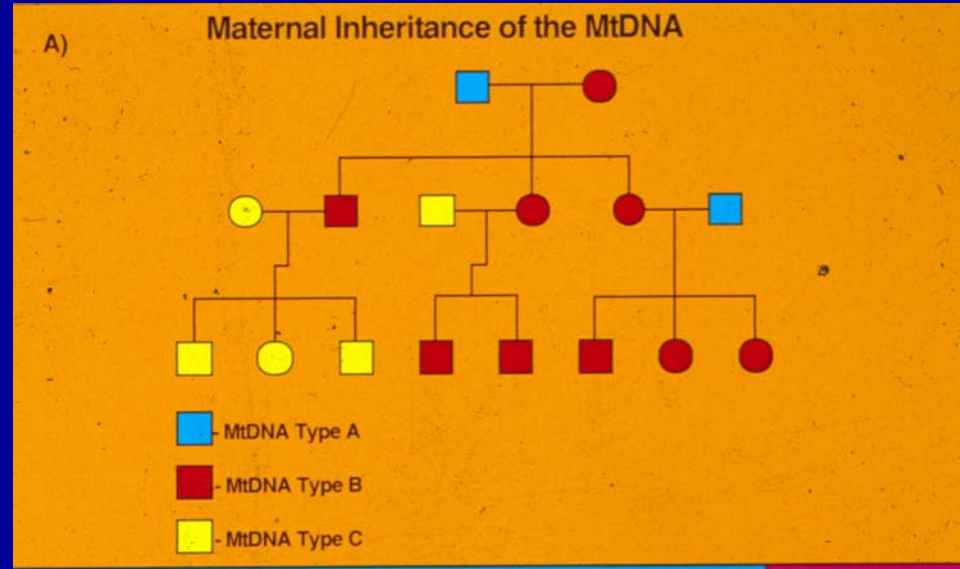
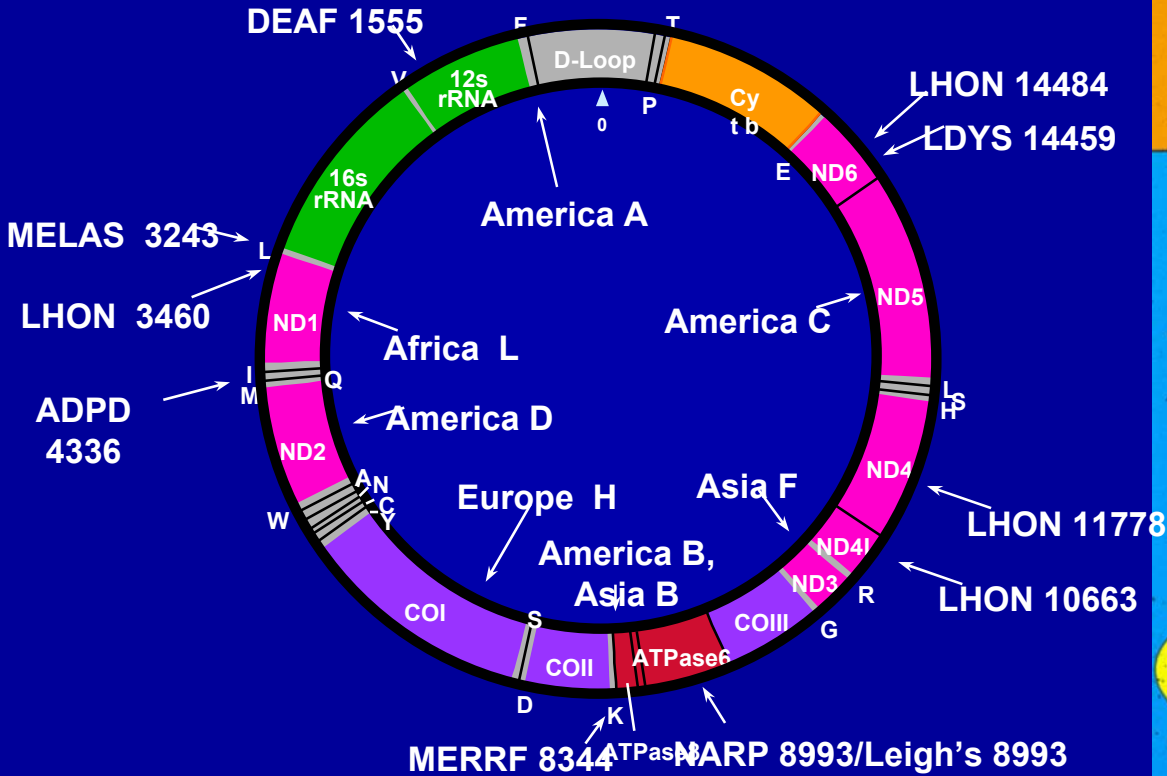

**PLANTS CHLOROPLASTS STORE SUN'S ENERGY-
ANIMAL MITOCHONDRIA RECOVER SUN'S ENERGY.**

**An Individual's mtDNA Gene Variants Determine the Amount of
Recovery Energy Used for Work Versus Heat.**

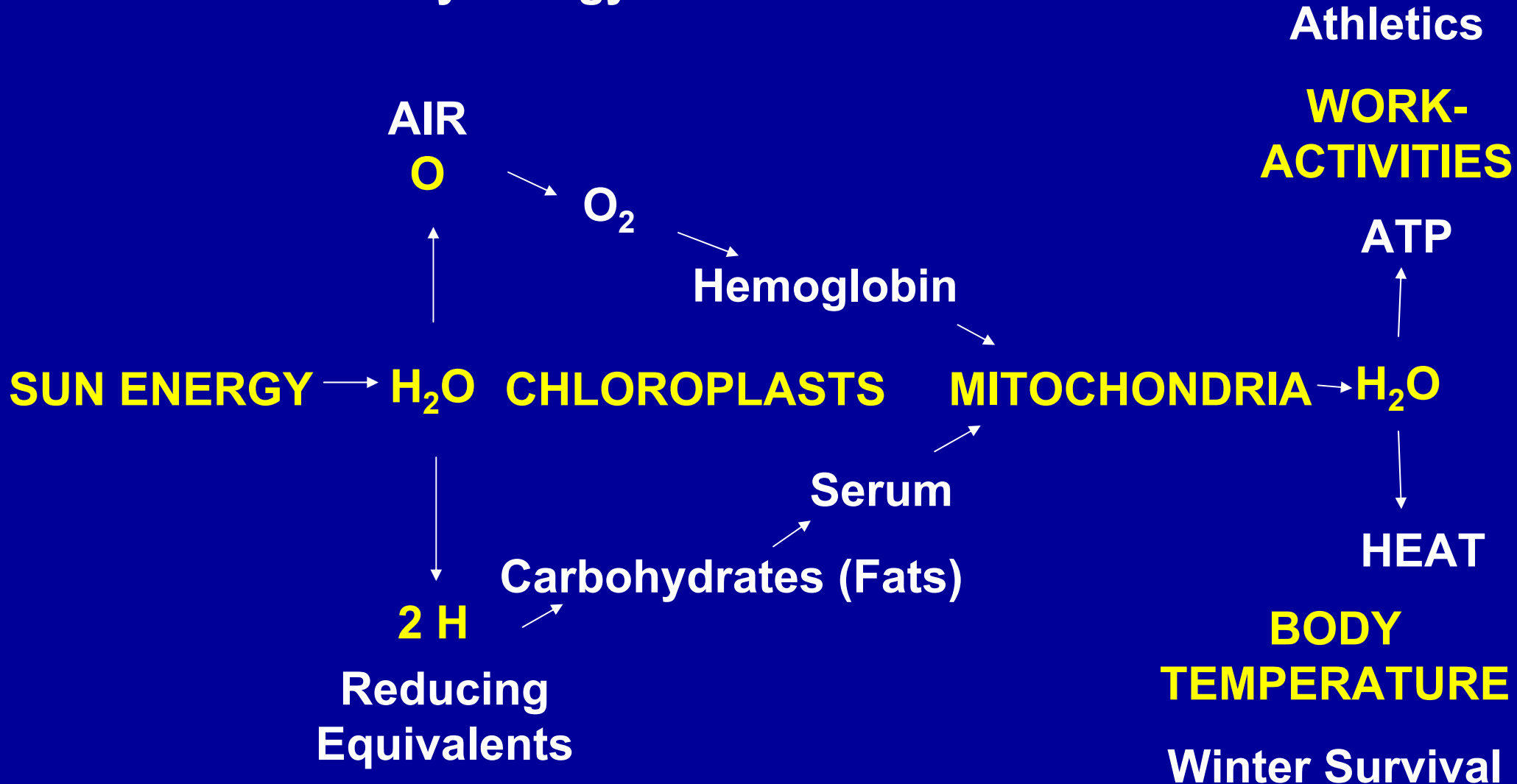

***Ant1* ^{-/-} Deficient Mice are Highly Fatigable**

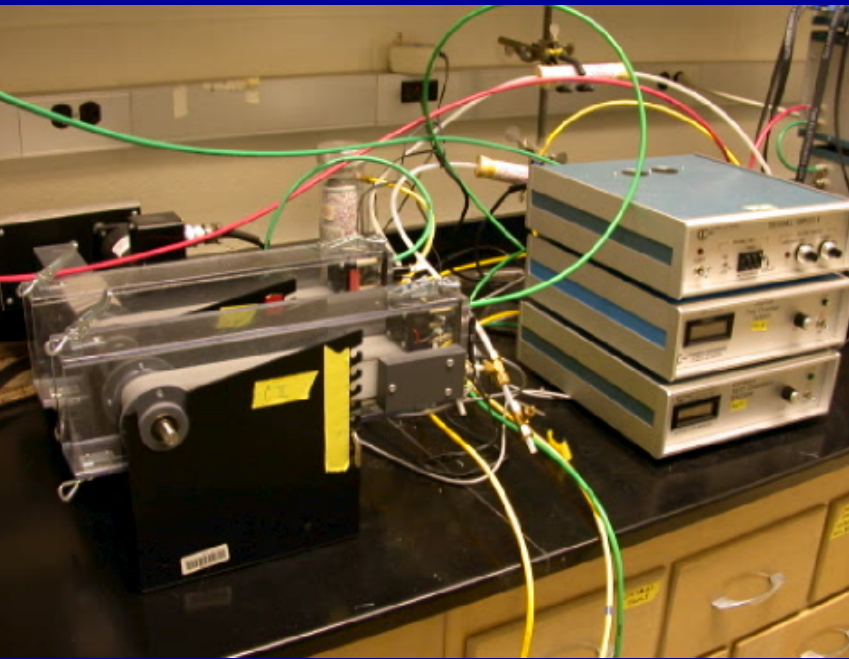

Mouserciser

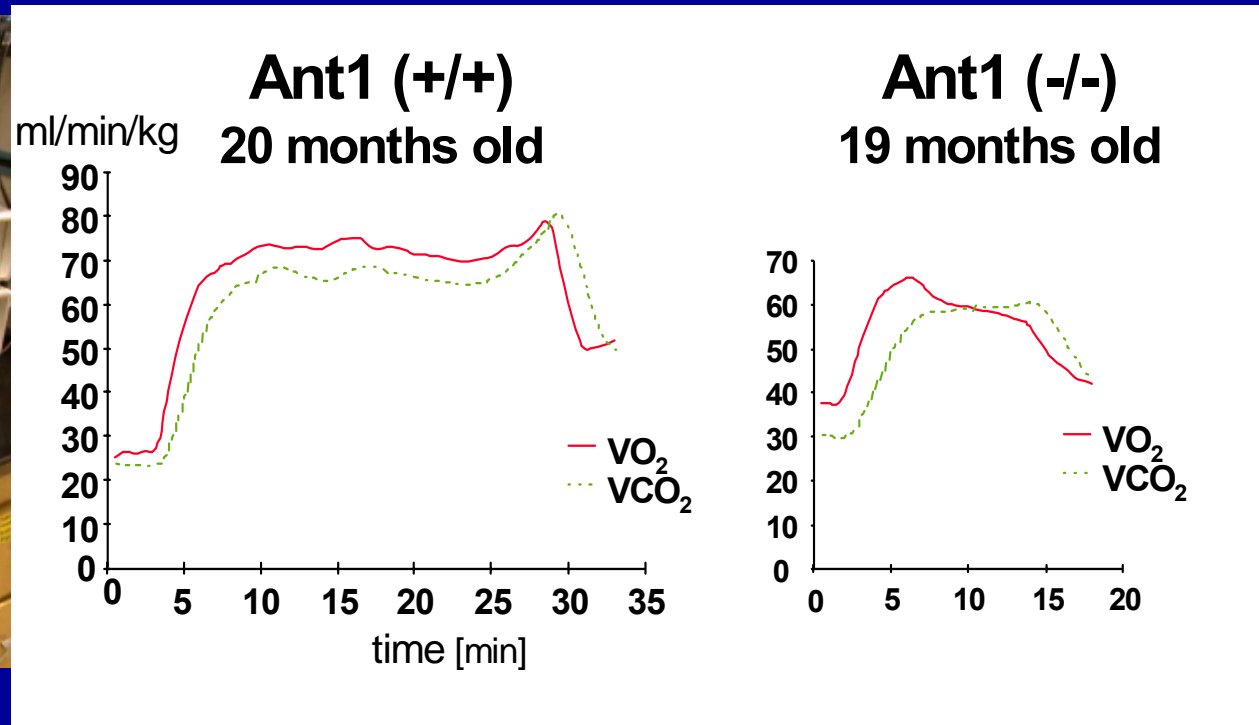

Exercise Stress Test Reveals Limited Endurance

AAV Transduction of *Ant1* cDNA (ADP/ATP Exchanger) Can Correct a Muscle Energy Defect

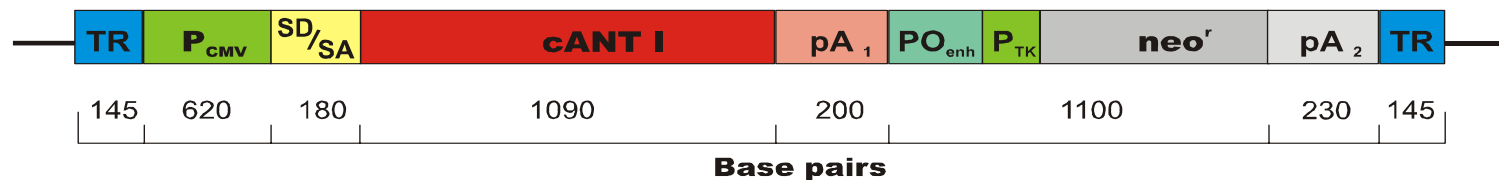
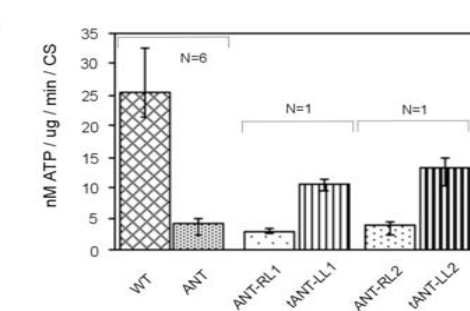
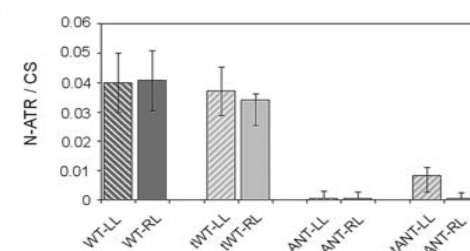
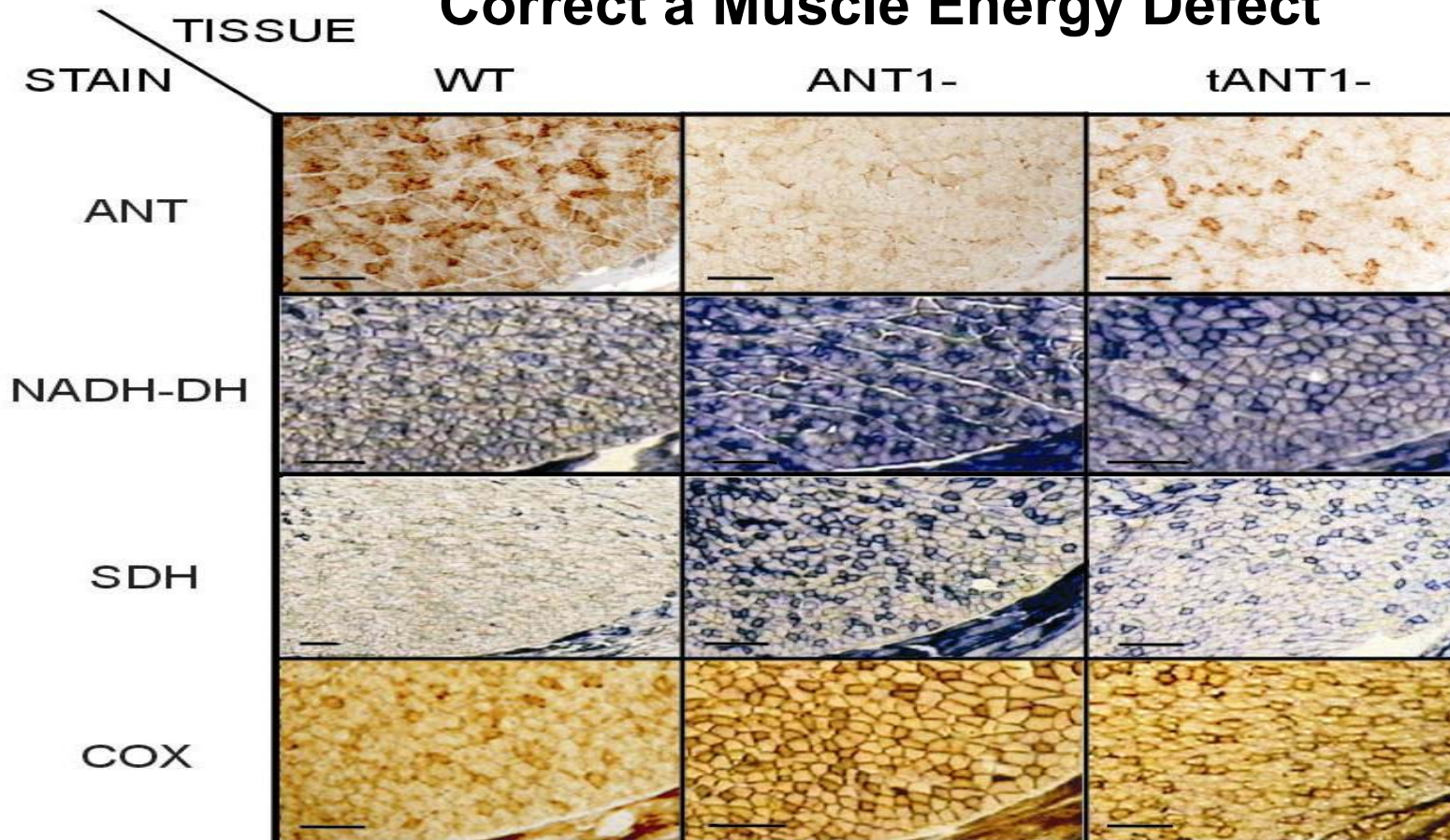

4.5 Kbp AAV cassette

AGING RATE IS PROPORTIONAL TO mtDNA MUTATION RATE

Mini Mouse

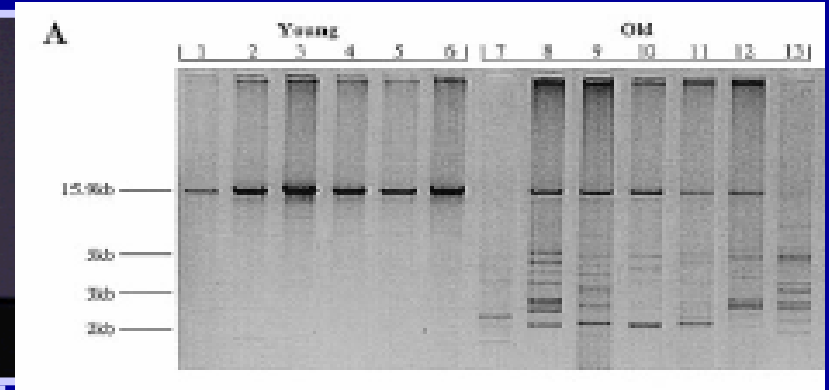
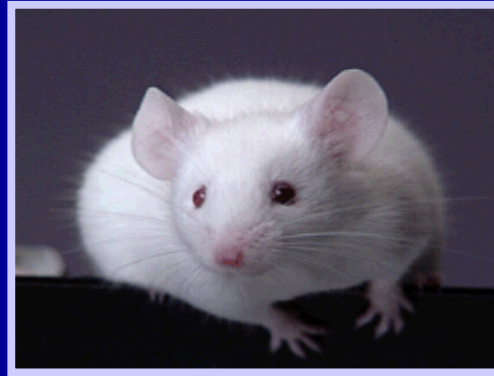

Milli Chimp

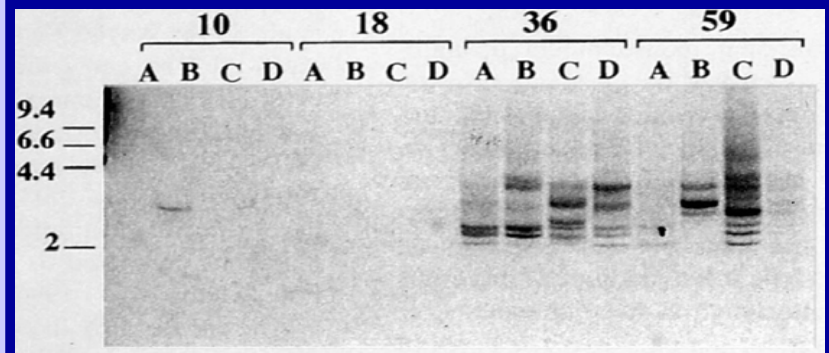

Charlie Darwin

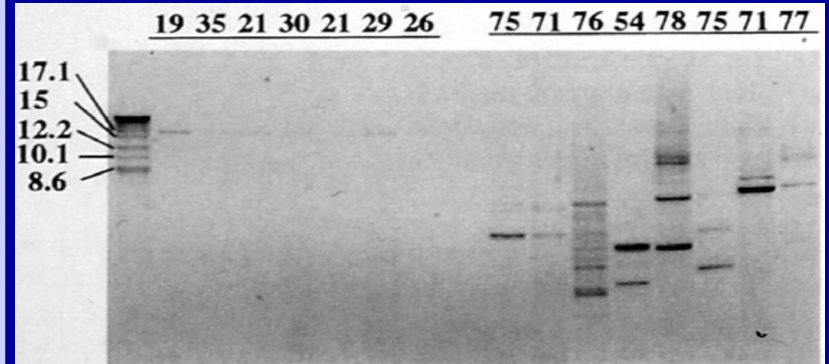
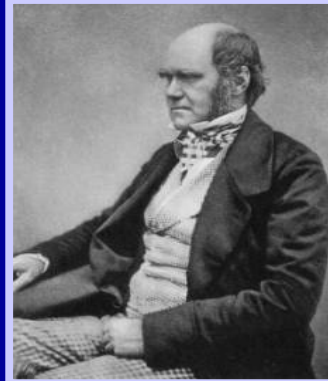

REDUCTION OF MITOCHONDRIAL ROS EXTENDS LIFE SPAN AND REDUCES mtDNA MUTATION RATE: Mitochondrially-Targeted Catalase (mCAT) Transgenic Mice

Pathology, U. Washington & MAMMAG, UCI



CMV
enhancer,
 β -actin
promoter

OTC N-
terminal mito.
targeting
peptide

Catalase
cDNA

Inactivate
peroxisome
targeting
peptide



Schriner S et al, 2005, Extension of murine life span by overexpression of catalase targeted to mitochondria. *Science* 308(5730):1909-11

The mCAT Transgene Increases Both Mean and Maximum Life Span

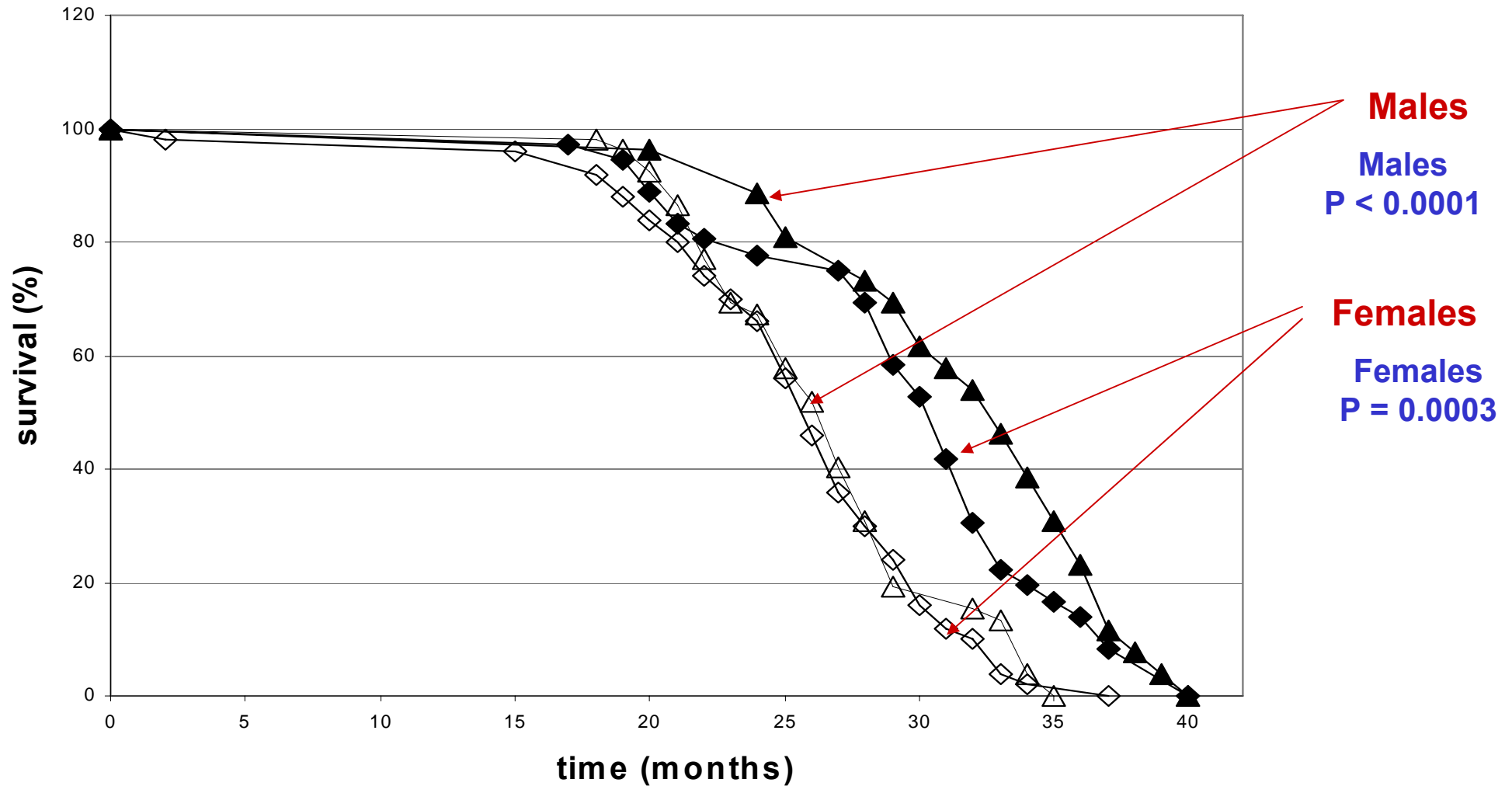

The mCAT Transgene Decreases Somatic mtDNA Rearrangement Mutations in Skeletal Muscle

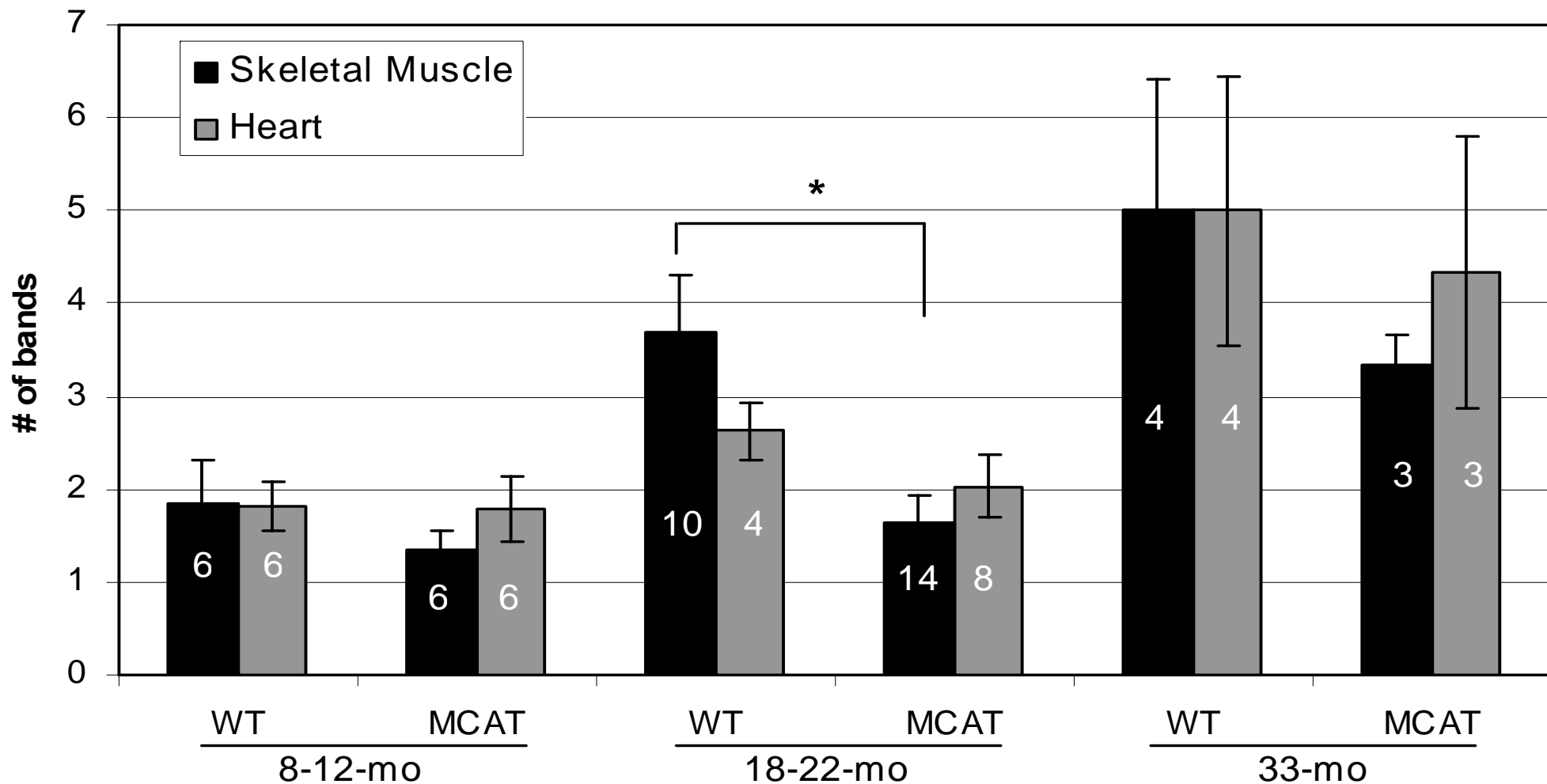

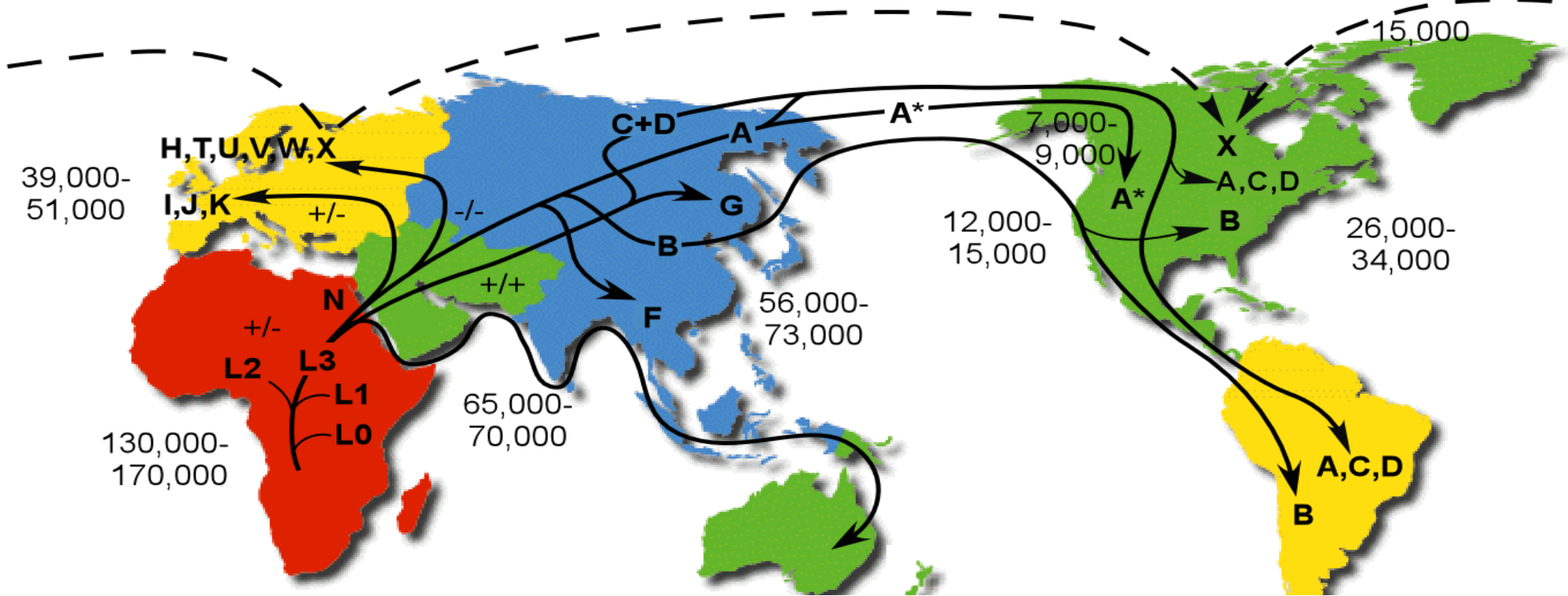

mtDNA Adaptive Polymorphisms Permitted People to Adapt to Colder Environments by Reducing ATP to make more Heat

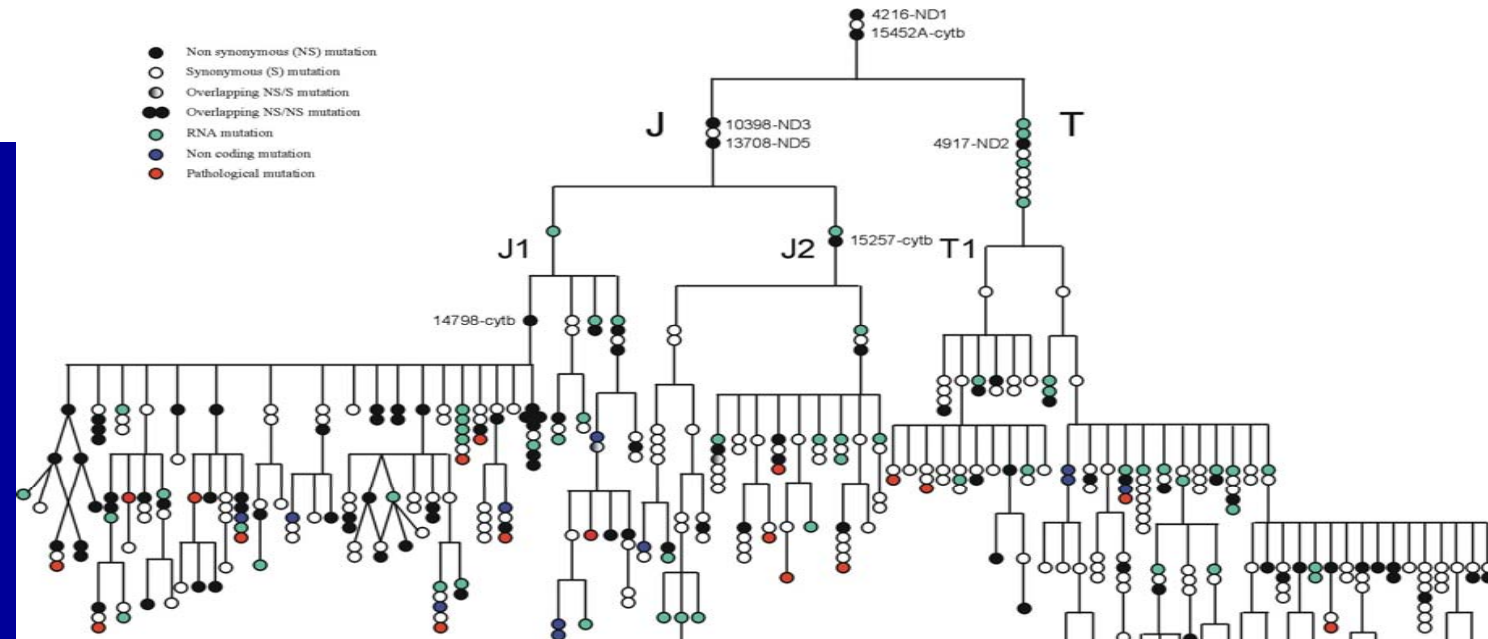

mtDNA Haplogroups Correlate with Longevity and Neurodegenerative Diseases

Mitochondrial haplogroups and longevity

Population	Mitochondrial Haplogroup	Reference
Japanese	D	Tanaka et al, 1998
French	K	Ivanova et al, 1998
Italian	J	De Benedictis et al, 1999
Irish	J / Uk	Ross et al, 2001
Finnish	J / U(Uk)	Niemi et al, 2003

Mitochondrial haplogroups and neurodegeneration

Population	Mitochondrial Haplogroup	Effect	Neurodegenerative disease	Reference
French-Canadian	T	Protective	AD	Chagnon et al, 1999
European-ancestry	J / U	Protective	PD	Walt et al, 2003
British	H	Susceptible	DLB	Chinnery et al, 2000

DLB.- Dementia with Lewy bodies

Potential mtDNA Sequence Alteration with Targeted Oligonucleotides

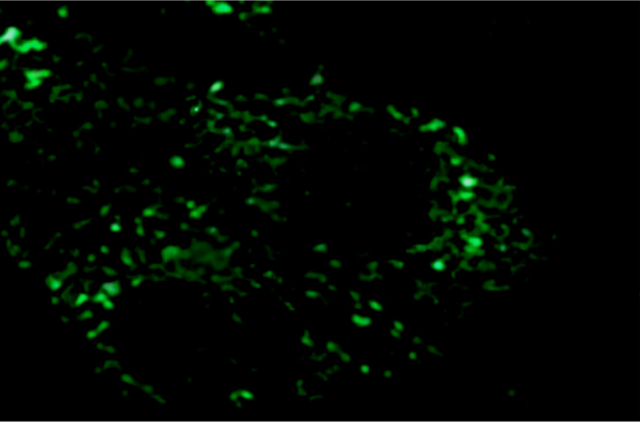
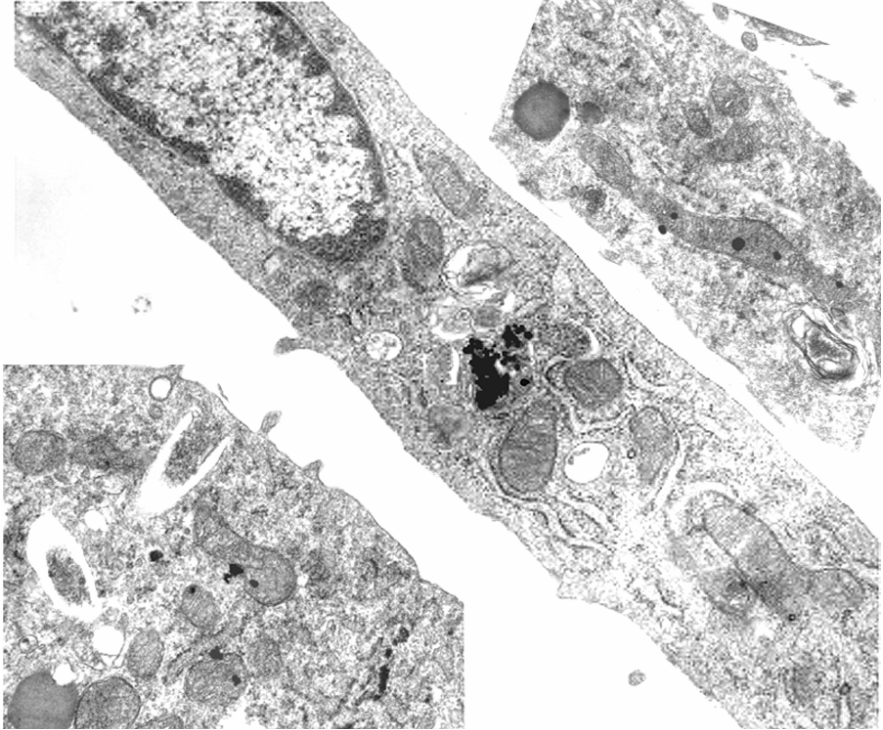
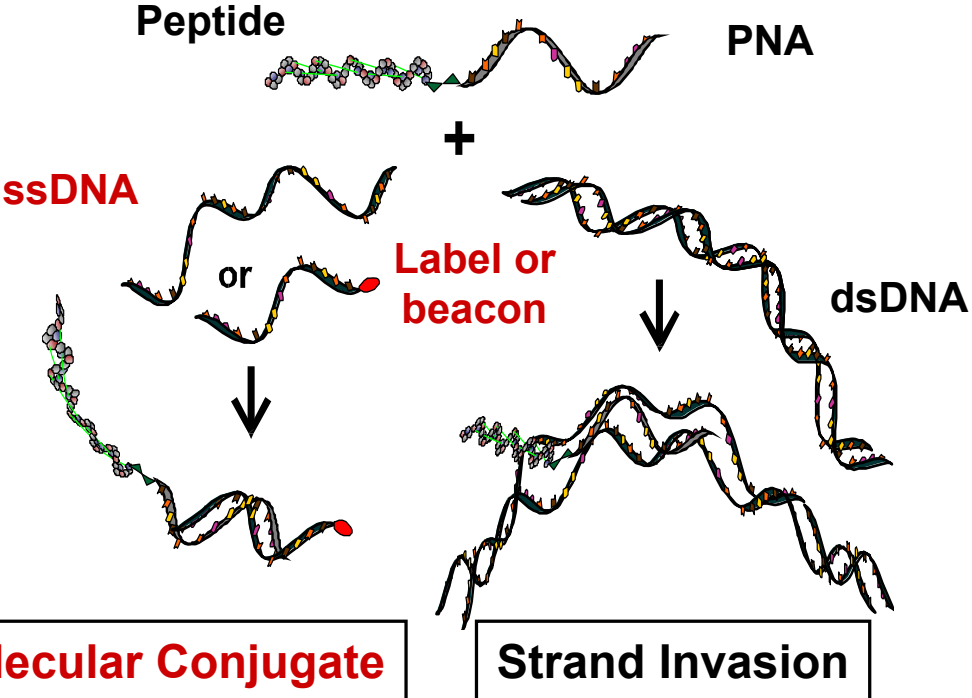

Conjugate + SL-O

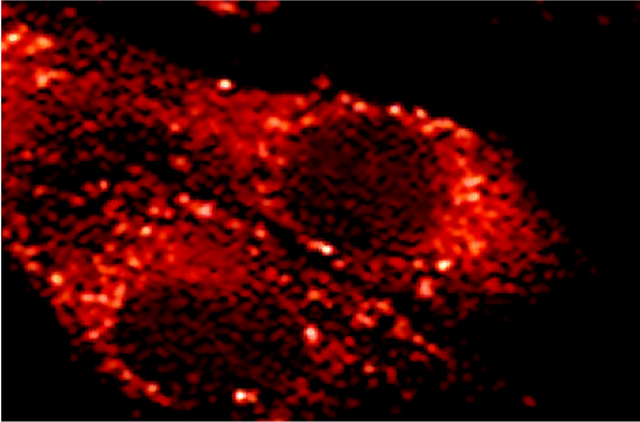

Mitotraker

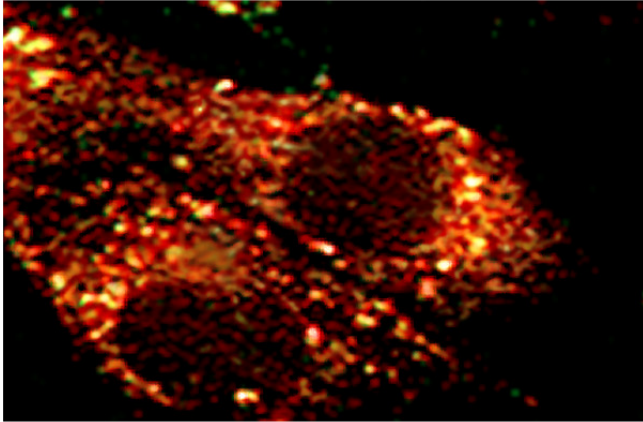

Overlaid



Thank You